

# Subsea Technologies For Ultra-Deepwater 'Subsea-To-Beach' Gas Field Development:

---

A Critical Review of Current Achievements  
and Future Challenges

Francesco Beltrami

Senior Technical Advisor – Subsea

Granherne Inc. (a KBR company)

Houston, TX, USA

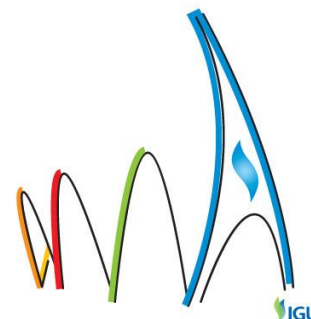

## Table of Contents

Table of Contents .....	1
Background .....	1
Aim .....	2
Methods .....	2
Results .....	3
Conclusions.....	13
References.....	14

### Background

Since its origins, the subsea industry has looked with great interest to all the technologies enabling the development of offshore oil and gas reservoirs without requiring host facilities such as fixed platforms, first, and floaters in more recent times.

The 'Subsea-to-Beach' approach to gas field development reached its maturity in the 90's and is currently adopted for major capital projects under development worldwide, including liquefied natural gas (LNG) projects. It has been also considered, in principle, for some extremely demanding environmental conditions, for example ultra-deepwater locations (over 1,000 m water depth), remarkable distances from the coast, and the Arctic environment.

Nowadays, 'Subsea-to-Beach' is seen as a viable option for offshore gas field development; nonetheless, floating LNG (FLNG) is becoming more and more popular as an alternative development 'building block' to be considered in some specific cases. FLNG is now in the commercial phase with several international projects either in execution or in early study stage.

To better discuss advantages and disadvantages of 'Subsea-to-Beach' versus FLNG in a given project, it is necessary to preliminarily investigate the readiness level, qualification status and market availability of the main components of the required subsea production system (SPS). This is one of the objectives of this paper.

The review identified the main technology gaps and the most critical challenges for the successful adoption of the 'Subsea-to-Beach' approach to the development of gas reservoirs in increasingly deeper waters and at very large step-out distances from the mainland.

Gaps and challenges are presented and critically discussed with respect to field development and as a part of a wider discussion on how to exploit deepwater gas reservoirs.

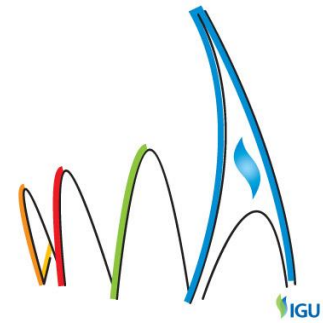

Technology readiness is only one of the factors to be considered when sanctioning an offshore project but it plays a critical role while assessing the feasibility of a given project within a pre-ordered timeframe. Being aware of the technologies currently available on the market will help operators to confidently narrow down the number of initial concepts created during Concept Selection. Looking at the future market trends will enable the subsea manufacturers to effectively develop the technologies required by the oncoming 'Subsea-to-Beach' projects.

### Aim

The objectives of this study are:

- The identification of the main technologies required by Subsea-to-Beach gas fields and in particular which are the key components of the subsea production system to be employed, see the section 'SPS Components',
- The investigation on the current technology gaps with respect to the increasingly challenging environmental conditions of the new projects, see the Results of Investigation, and
- The discussion of the technologies needed by the future Subsea-to-Beach projects, see the section 'Future Trends'.

### Methods

The six steps followed in this study can be summarized as follows:

- Illustration of the subsea projects investigated, including some examples of the most known Subsea-to-Beach projects using information available in the public domain<sup>1</sup>,
- Review of historical developments associated with LNG production and other cases,
- Definition of the enabling technologies and of the required SPS components,
- Investigation on the current status-of-the-art and market availability for such key components,
- Presentation and discussion of the main results obtained, and
- Future trends: what lies ahead?

---

<sup>1</sup> No operators or subsea manufacturers have been contacted in preparing this review.

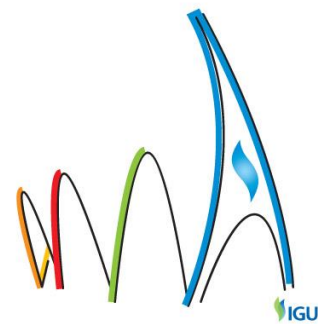

## Results

### Subsea-to-Beach Projects

A typical Subsea-to-Beach gas field development is shown in Figure 1, while the schematic of the subsea production control system at the onshore terminal is presented in Figure 2. The number of subsea wells will vary in the different projects, but the main components of the subsea production system are likely to be the same.

Selected examples of different offshore gas development projects are presented in Table 1 (notable long subsea tiebacks for gas fields), Table 2 (current and ongoing Subsea-to-Beach) and Table 3 (future Subsea-to-Beach).

Long gas subsea tiebacks and Subsea-to-Beach projects are different from gas gathering networks that collect and transfer treated gas from offshore hosts to an onshore terminal, usually in mature provinces. See for example the Block 15, 17 and 18 gas gathering systems feeding the Angola LNG plant. Gas gathering networks are not discussed in this paper; long gas subsea tiebacks are discussed with respect to the technologies that made them possible, as these technologies are relevant to Subsea-to-Beach projects.

'Subsea-to-Beach' projects are unique because of their:

- Lack of offshore host (fixed platform in shallow water, floater in deeper waters) and therefore of production risers, which are usually part of the SPS,
- Multiphase flow, wet gas with liquids (not processed offshore),
- Natural flow, no offshore or subsea compression (though may require compression at a later stage of field life),
- No pipeline insulation; need to inject MEG constantly to prevent hydrate formation,
- Long step-out distances from subsea wells to onshore terminal,
- Large volumes of gas to be handled: great number of subsea wells in some cases, very large productivity of individual subsea wells in other cases,
- Need for engineered shore approach.

Ultra-deepwater Subsea-to-Beach projects (1,000 m WD and more) also require:

- Transition from deep offshore to continental shelf affecting pipelines design,
- Power and communication distribution over long distances.

Subsea-to-Beach projects share with long gas subsea tiebacks the step-out distance range, within 200 km, see Figure 3, but at present their water depth (WD) is limited below 1,500 m.

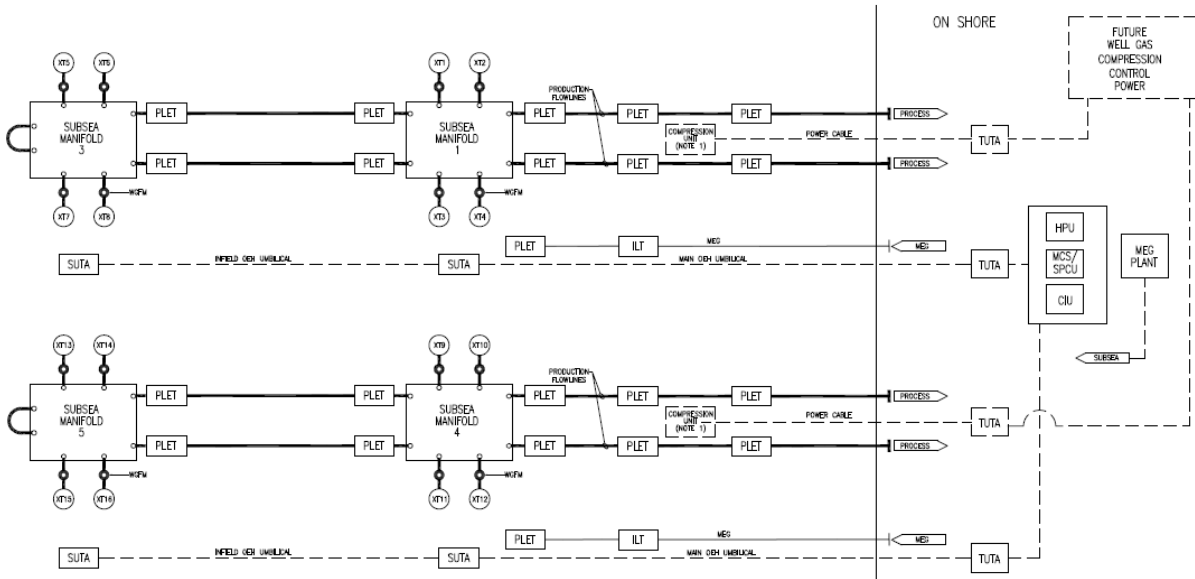
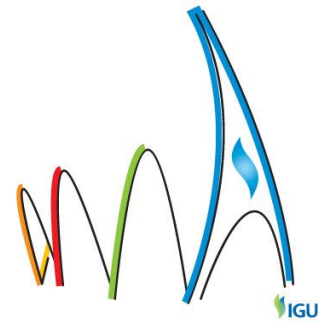

Note 1: subsea compression to be added in the future, including the required onshore equipment.

Abbreviations: in-line tee (ILT), pipeline end termination (PLET), subsea power and communications unit (SPCU), subsea umbilical termination assembly (SUTA), subsea tree (XT).

**Figure 1 – Subsea-to-Beach Gas Field SPS c/w future Subsea Gas Compression**

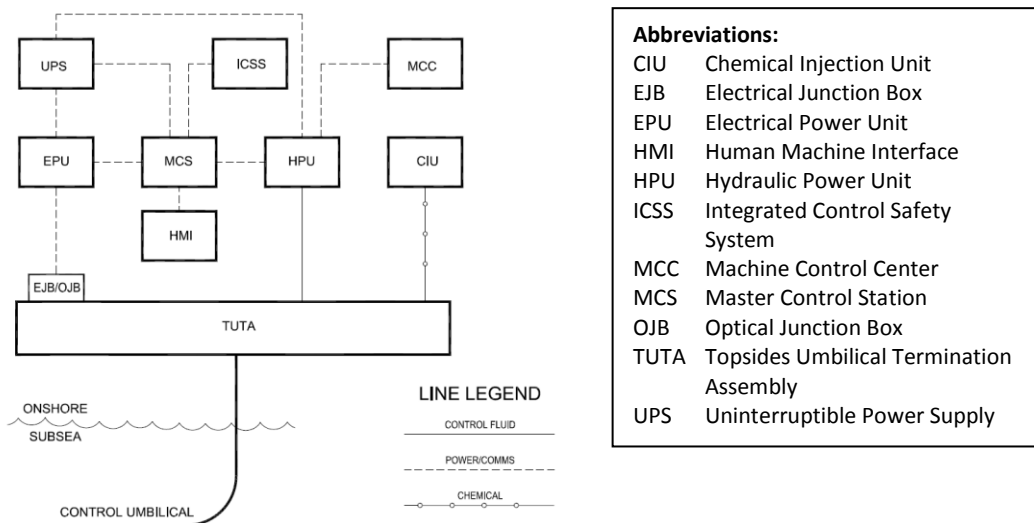

**Figure 2 – SPS Control System in Onshore Plant (MEG not shown)**

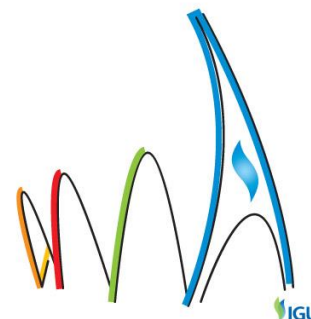
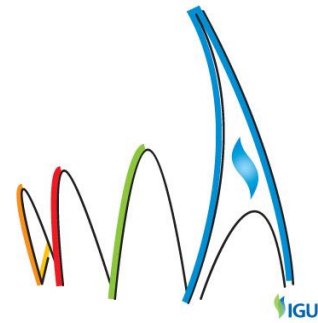

**Table 1 - Selected Long Gas Subsea Tieback Projects**

Year	Operator	Field	Location	Water Depth (m)	Step-out (km)	Notes
2018E	Noble Energy	Leviathan	Mediterranean Sea	1,500	130	
2015E	Noble Energy	Tamar SW	Mediterranean Sea	1,700	148.8	
2014	Husky Oil	Liwan	South China Sea	1,500	75	
2013	Noble Energy	Tamar	Mediterranean Sea	1,700	148.8	
2012	Woodside	Pluto	Western Australia	850	190	LNG
2002	Total	Canyon Express	Gulf of Mexico	2,195	100	
1997	Shell	Mensa	Gulf of Mexico	1,615	110	

**Table 2 – Selected Current and Ongoing Subsea-to-Beach Projects**

Year	Operator	Field	Location	Water Depth (m)	Step-out (km)	Notes
2015E	Chevron	Gorgon	Western Australia	200	65	LNG
2015E	Chevron	Jansz-lo	Western Australia	1,350	180	LNG
2015E	Shell	Corrib	Atlantic Ocean	355	70	
2015E	Total	Laggan-Tormore	Atlantic Ocean	600	143	Phase I
2013	Gazprom	Kirinskoye	Sea of Okhotsk	90	28	
2013	BHP	Macedon	Western Australia	180	75	
2013	Tullow Oil	Kudu	Atlantic Ocean	170	170	
2010	Santos	Vic/ P44	Western Australia	70	55	
2009	BG Group	Sequoia	Mediterranean Sea	570	120	LNG, WDDM VI
2008	bp	Taurt	Mediterranean Sea	108	72	
2007	Statoil	Snohvit, Albatross	Barents Sea	345	178	LNG
2007	N. Shell	Ormen Lange	North Sea	1,100	120	
2005	BHP	Minerva	Victoria (Australia)	60	11	
2005	BG Group	Sapphire	Mediterranean Sea	1,100	120	LNG, WDDM III
2005	BG Group	Simian, Sienna	Mediterranean Sea	1,100	120	LNG, WDDM II
2003	BG Group	Scarab, Saffron	Mediterranean Sea	850	90	WDDM I
1981	Eni	Emilio	Adriatic Sea	84	32	



**Table 3 – Selected Future Subsea-to-Beach Projects**

Year	Operator	Field	Location	Water Depth (m)	Step-out (km)	Notes
2019E	Anadarko	Prosperidade	Mozambique	1,500	50	LNG
2019E	Anadarko	Golfinho	Mozambique	1,500	100	LNG
TBD	Gazprom	Shtokman	Barents Sea	340	600	FPU?
TBD	Statoil	Block 2	Tanzania	2,400	80	LNG
TBD	BG Group	Various	Tanzania	2,000	100	LNG
TBD	Total	Laggan-Tormore	Atlantic Ocean	600	143	Phase II
TBD	Chevron	Greater Gorgon	Western Australia	300	188	LNG

E = Expected

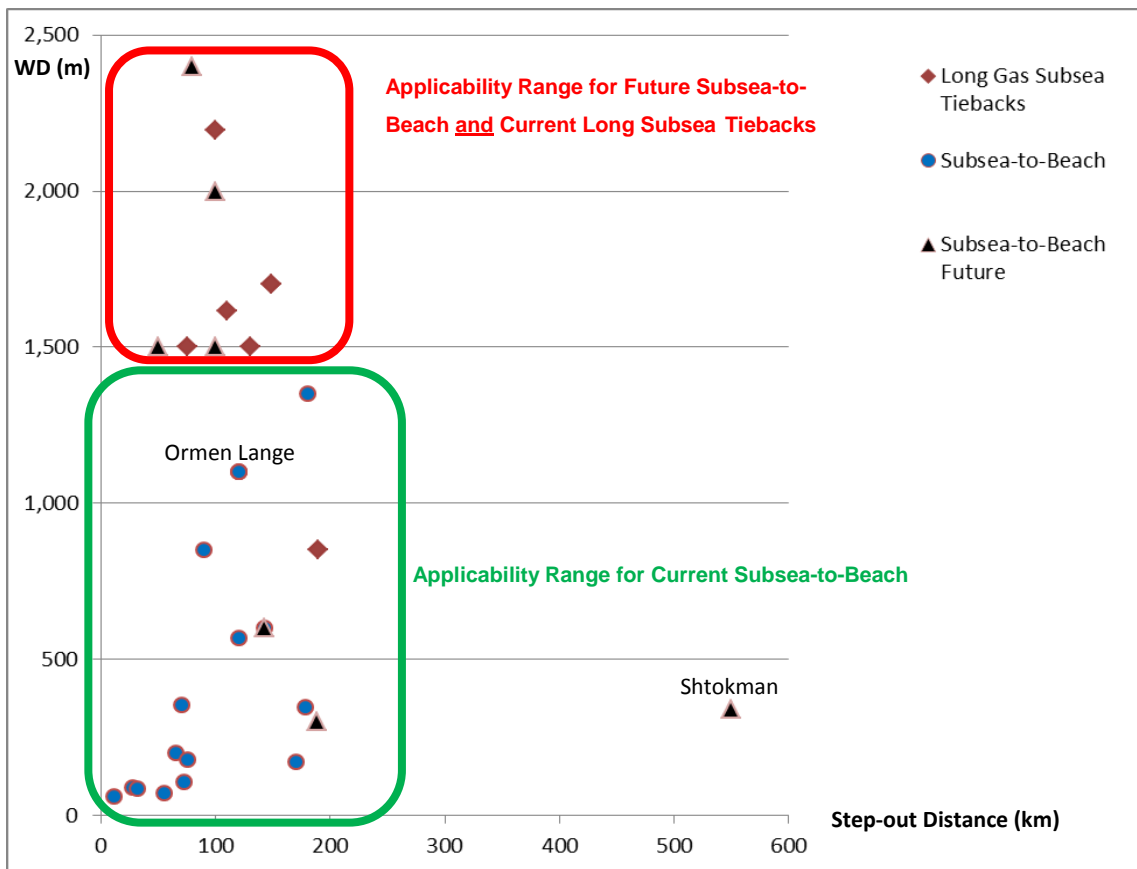

**Figure 3 – Subsea Tiebacks and Subsea-to-Beach Chart**

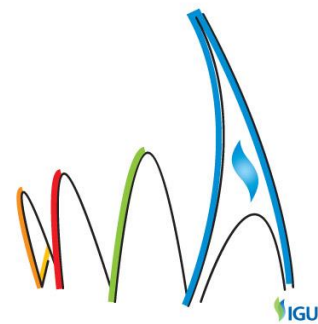

Only two project names are indicated in Figure 3: Gazprom Shtokman, a real 'outlier' with respect to the other projects reviewed here, was intended to be a very long Subsea-to-Beach development in Arctic environment coupled to onshore LNG, but is now understood to be utilizing a Floating Production Unit (FPU) to process the gas before the long export due to the coast. Shtokman was also a possible candidate for subsea gas compression as well as Ormen Lange: however, in 2014 it was announced that the Norske Shell Ormen Lange subsea compression project was suspended.

Figure 3 also shows an interesting fact: some of the subsea technologies required for future ultra-deepwater Subsea-to-Beach projects have been already employed in past and existing long gas subsea tiebacks. Despite the challenges to produce gas reservoirs in 1,500 to 2,000 m WD at a 200-km distance from the coast, technologies and operational lessons learned are available to the industry as a valid starting point.

A second useful starting point is the technical experience gathered, over the past years, with shallow water Subsea-to-Beach projects. Several of the projects presented in Table 2 and shown in Figure 3 are shallow water projects. This is why these projects are mentioned in a paper that, intentionally, focuses on the technologies required for ultra-deepwater Subsea-to-Beach projects.

It is not possible to describe in a detailed way all the projects listed in Table 1 to Table 3. When a second phase of a project has been announced, it has been considered as a distinct project (see for example Chevron Gorgon and Greater Gorgon developments). Technical information is available in literature about some of the most famous projects mentioned here: a few selected references are indicated in the References section.

WDDM refers to the West Delta Deep Marine concession offshore Egypt operated by the BG Group. WDDM had several development phases, either addition of new fields or addition of new infill wells drilled in the existing fields. The WDDM is a good example of the flexibility of subsea production systems that, if properly designed, can accommodate future production by enabling subsequent expansions or reconfigurations.

### **Subsea-to-Beach and LNG Projects**

As shown in Table 2, the only existing project with a Subsea-to-Beach development coupled to an onshore LNG plant is the Statoil Snohvit, Albatross and Askeladd development. There are a few similar projects under development across the world. They are:

- Chevron Gorgon and Jansz-lo in Western Australia,
- Anadarko Prosperidade and Golfinho in Mozambique,
- BG Group, and possibly Statoil, in Tanzania – different offshore blocks.



### SPS Components

The typical subsea production system for Subsea-to-Beach application is shown in Figure 1. The subsea wells are connected to subsea manifolds by means of well jumpers. In turn, manifolds are connected to the production flowlines by means of flowline jumpers. The detail of a typical deepwater drill center is presented in Figure 4.

Dual flowlines are often specified: in this case manifolds are equipped with two production headers and with a pigging loop that permits the pigging operations of the two flowlines. In some projects, a single flowline has been specified. In this case, pigging is possible only by positioning a subsea pigging trap to launch pigs toward the onshore plant. Flowlines are usually not thermally insulated due to the great distances between the wells and the onshore terminal. The formation of methane hydrates is prevented by means of continuous injection of mono-ethylene-glycol (MEG) into the wellstream. Dedicated stand-alone MEG pipelines are constructed to ensure that the adequate amount of MEG is injected at each subsea well.

Subsea trees and manifolds are operated by means of a subsea production control system consisting of onshore equipment, control umbilicals, complete with terminations, and flying leads from the umbilical terminations to the subsea hardware.

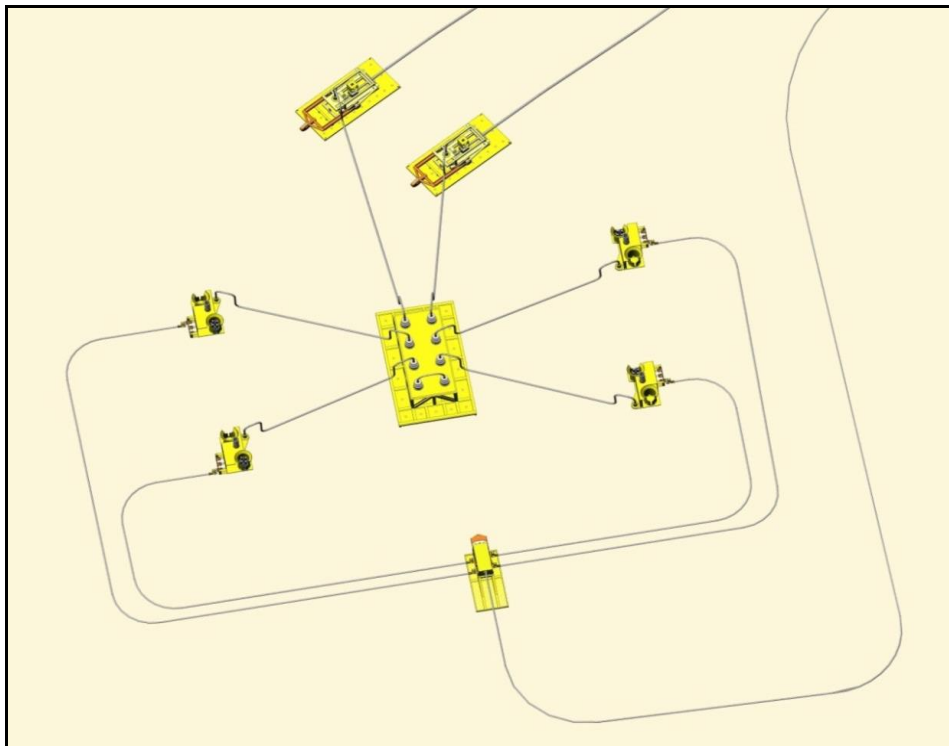
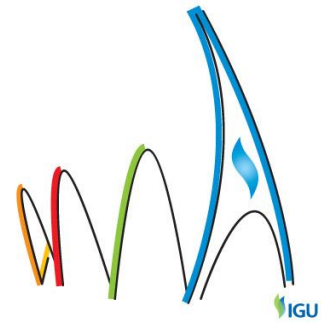

Figure 4 – SPS Components in Ultra-Deepwater Drill Center



The SPS typically consists of:

- Subsea Trees c/w chemical injection metering valves (CIMV), production choke valve (PCV) and wet gas flowmeters (WGFM),
- Subsea Manifolds (with instrumentation, controls and valves) c/w foundations,
- Subsea Tie-in System (hubs and mating connectors),
- Well Jumpers and Flowline Jumpers,
- Infield Flowlines and Main Trunklines c/w terminations,
- MEG pipeline, MEG flying leads and distribution units,
- Optical-Electro-Hydraulic (OEH) multiplexed control umbilicals c/w terminations, and subsea distribution units as applicable,
- Flying Leads (hydraulic, chemical, electrical, optical),
- Onshore Controls including the master control station (MCS), the hydraulic power unit (HPU), one 'topsides' umbilical termination assembly (TUTA) for each umbilical, and all the other components shown in Figure 2.

These components have been investigated with respect to their technology readiness status and market availability. Inspection and intervention technologies are not listed above but have been investigated due to their impact on offshore construction and field life operations.

### State of the Art and Market Availability

Nowadays, subsea hardware and controls are designed for 3,000 m WD even when used in shallower waters. Technology qualifications programs, according to API or DNV, are carried out as applicable to ensure that the subsea technologies that are not field-proven for a given project undergo a complete test program to confirm their fitness for purpose.

There are three different designs for **Subsea Trees**: conventional (or vertical) tree with dual-bore tubing hanger, conventional tree with mono-bore tubing hanger and horizontal tree. Pressure ratings are 10,000 psi and 15,000 psi. Typical sizes are 5"x2" and 7"x2", where the first digit refers to the diameter of the tree production bore and the second digit to the size of the tree annulus bore. Broadly speaking, subsea trees appear to be field-proven for ultra-deepwater application, but the large 7"x2" trees required for large productivity gas wells may require technology qualification to confirm that they meet all the project requirements and possess the adequate technology readiness level for the intended use. 4"x2", 10,000 psi, all electric horizontal tree(s) were installed in 2008 to produce a very shallow water gas field.

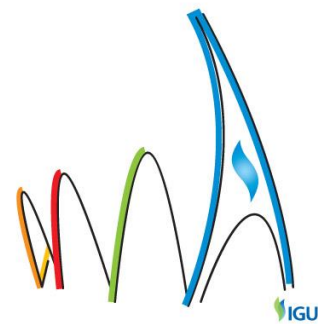

A recent trend observed in the subsea industry is to install both the **Production Choke Valve** and the **Wet Gas Flowmeter** on a module that can be retrieved independently from the subsea tree. If one of these two components fails during the field life, the module is retrieved to surface and replaced by a back-up unit. This minimizes the downtime associated to the repair intervention. PCV's and WGFM's have been extensively used in several subsea projects and therefore they only require, on a project-by-project basis, a limited technology qualification program to confirm their readiness.

Subsea **Chemical Injection Metering Valves** have been used in several deepwater and ultra-deepwater projects in order to reduce the number of individual chemical injection lines in control umbilicals and make the umbilicals smaller. A unique chemical injection line can now feed multiple CIMV's, one for each subsea tree. On the market there are different types of subsea metering valves that adopt diverse operational principles and designs. These valves come with different pressure ratings, injection flowrates - very large flowrates may be required for MEG injection and construction materials: for this reason it will be possible to choose from different technologies in order to meet the project's needs.

Single-header and dual-header **Subsea Manifolds** can be considered as field-proven components too. Manifolds are project-specific units designed to match with the number of wells and with the size of the flowlines they are connected to. Similarly, the subsea foundations for manifolds can be considered as field-proven equipment (both mudmats and suction piles). Manifolds and their foundations will be designed on the basis of the project environmental data and the intended service. Nowadays manifolds are equipped with instrumentation, such as a pig detector and pressure and temperature sensors, and remotely-actuated valves, in addition to ROV-operated valves, and for this reason they may require a dedicated subsea control module (SCM). In some cases, the controls for the manifold are provided by the SCM's on the nearby subsea trees.

**Subsea Valves** are typically gate valves, up to 7" size, and ball valves from 7" to very large sizes (required for export trunklines or other large diameter pipelines). Considering the great number of combinations of size, pressure rating, past project applications, and materials, it can be expected that in an ultra-deepwater project, subsea valves undergo a relatively short qualification program to confirm that the ones selected possess the proper technology qualification level. Subsea valves are generally piggable and can be fitted with hydraulic actuators, more commonly, or electric actuators, more recent technology that is gaining wider and wider acceptance. Electric actuation may be one of the 'game changers' of the future.

Vertical or horizontal **Subsea Tie-in Systems** are currently available on the market with clamp types and collet types and multiple sealing principles, connector sizes, pressure ratings, materials and application history. As seen for subsea valves, subsea connectors typically undergo a short qualification program (approx. four weeks) to confirm that those selected for a given project possess the proper technology qualification level.

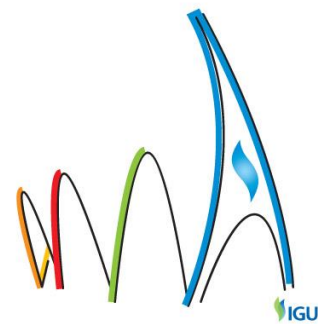

**Well Jumpers** are typically 6" or 8" in diameter and 30 m long (ranging between 15 m and 45 m). **Flowlines Jumpers** have different sizes and lengths according to the flowlines they are connected to. Well and Flowline Jumper are often rigid, but flexible jumpers can be used in case of wells located a few hundred meters away from the manifold. No issues are seen with respect to jumpers.

**Flowlines, Pipelines and Trunklines** are designed according to API or DNV codes and standards to meet the project requirements. Terminations are provided with hubs to connect jumpers, and valves to be used to isolate a line if required during the field life. The design of long pipelines and trunklines can be challenging especially if the wells are far from the coast and there is a transition from the deep offshore seabed to the continental shelf. Another challenge in pipeline design is the shore approach and crossing, as this requires specialized technologies to minimize the impact on the environment. Pipelines need to be piggable with smart pigs. Even if the design and the installation of these ultra-deepwater pipelines may be challenging, the current technologies permit deeper waters and longer step-out distances. A special pipeline is the MEG pipeline used to transfer MEG from the onshore terminal to the offshore location(s). This smaller size pipeline is usually piggy-backed to a larger production pipeline. The MEG leaving the MEG pipeline enters an infield control umbilical: for this reason, MEG cleanliness may be an issue.

**Control Umbilicals** contain multiple hydraulic and chemical tubes to supply control fluid and chemicals respectively; power and communication (on copper) quads and fiber optics (for large data volume communications). Considering the long step-out distances of these projects, umbilical costs are relevant. Electro-hydraulic multiplexed control systems are mature technologies even if the exchange of data and power distribution over long distances is still challenging. Subsea transformers will be needed to ensure the required electric power is effectively available on the seabed. Large umbilical cross sections will be required for high power distribution over long distances. Another challenge for control umbilicals is the maximum length that can be produced without splicing (in some cases it is not possible to manufacture the required length in one run and splicing cannot be avoided). The size, weight and complexity of some deepwater umbilical terminations have increased over time: it might be necessary to re-think these terminations, and also how subsea distribution units are designed.

**Flying Leads** connect the umbilical termination to the subsea tree or subsea manifold. Hydraulic, chemical, electrical and optical flying leads can be designed with different types of couplings and connectors that are currently available on the market. Technologies are currently under development to meet more demanding project's requirements. Flying Leads and their connection systems are not 'show stoppers'.

The main onshore components of the subsea production control system (**Onshore Controls**) are the MCS, the EPU, the production HPU and the TUTA. These, and the other components shown in Figure 2, are currently available on the market. The challenges mentioned above for the control umbilicals apply to these components of the subsea production control system (large volume data transfer and subsea power distribution).

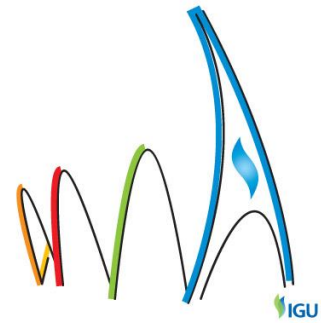

**Autonomous Underwater Vehicles (AUV's)** and Remotely Operated Vehicles (**ROV's**) are currently used in ultra-deepwater to carry out inspection or intervention services on the subsea production system and can be considered as mature technologies. Similarly, the **Installation and Workover Control System (IWOCS)** required for subsea well completion and workover is based on field-proven technologies. There are no issues about AUV's, ROV's and IWOCS.

### Results of Investigation

The main technical challenges for ultra-deepwater Subsea-to-Beach gas developments appear to be:

- Possible need for offshore (host) or subsea gas compression when the subsea wells start depleting. Offshore compression is technically feasible while, at this time, subsea gas compression is not yet a mature technology. Norske Shell Ormen Lange subsea compression project has been recently suspended, while Statoil Asgard and Statoil Gullfaks subsea compression projects are currently under development. The operational results of these two new projects will help understanding if in the future subsea gas compression becomes viable for ultra-deepwater Subsea-to-Beach projects,
- Subsea power distribution equipment and power cables (large cross sections), especially in case of subsea gas compression where tens of MWs are required at the seabed,
- Reliable high-speed subsea communications over long distances capable of handling increasingly larger data volumes due to intelligent well completions and subsea sensors (such as WGFM, sand detector, etc.),
- MEG cleanliness control after regeneration (including possible subsea filtration systems); MEG dosing to ensure proper hydrate formation prevention; cocktailing of MEG and other chemicals, if possible, to limit the number of chemical tubes in the control umbilicals,
- Obsolescence of electronic components and backward compatibility of new controls equipment added to the subsea production system: this is an issue for all SPS's but is here more relevant because the design life of Subsea-to-Beach projects is shifting from the usual 20-25 years to 30 years and above: for example, it is understood that the design life for Chevron Gorgon pipelines is 50 years.

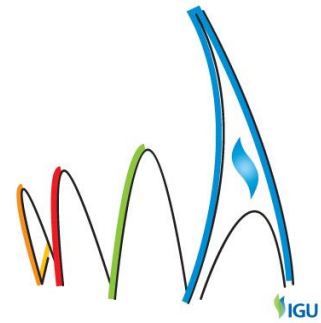

### Future Trends

To be successful in deeper waters, over longer step-out distances and in more demanding environments, Subsea-to-Beach projects are likely to employ the following technologies once in their commercial stage:

- Electric actuation for subsea valves on subsea trees (all-electric tree), manifolds and other hardware. Removing hydraulic lines from the control umbilicals will make them smaller and therefore less expensive, while system reliability is expected to increase,
- Subsea Chemicals Storage. This is another way to reduce the size and the cost of control umbilicals: if chemicals can be stored on the seabed and from there injected into the wellstream, the umbilical chemical tubes are not required anymore,
- Deepwater high-integrity pressure protection system (HIPPS): this technology is obtaining a wider acceptance and is beginning to be used in deepwater projects, i.e. in the Gulf of Mexico and possibly the Mediterranean Sea. HIPPS enables a less conservative pipeline design resulting in financial savings without compromising to operational safety. An incremental improvement might be the all-electric HIPPS which was studied for ultra-deepwater applications,
- Subsea heat exchangers to cool hot gas and avoid more expensive materials, such as corrosion resistant alloys (CRA's), for pipelines and subsea hardware, especially if coupled with corrosion monitoring systems (field-proven technology),
- AUV's permanently resident on the seabed and remotely controlled for inspection, intervention and repair activities on the SPS components,
- Riserless well intervention in an ultra-deepwater environment. So far, riserless intervention techniques (slick line, wireline and coiled tubing) have been successfully used in shallower waters many times, but new vessels will be soon available on the market to perform riserless intervention on ultra-deepwater wells.

### Conclusions

The review of the subsea technologies currently used in Subsea-to-Beach projects and in long gas subsea tiebacks leads to these conclusions:

- No major technical challenges appear to be associated to ultra-deepwater projects up to 1,500 m WD and 200 km step-out distance from the mainland,
- Some technical challenges for future Subsea-to-Beach projects in deeper waters (from 1,500 m WD on) can be expected in terms of subsea power distribution, subsea communications, MEG handling,

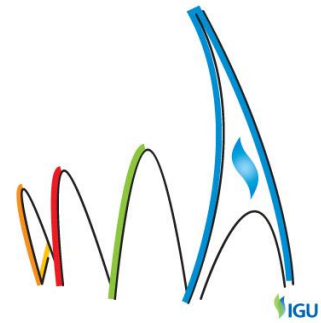

- Historically, the evolution of subsea technologies has always been rapid and effective in meeting projects' needs, so it is likely that when new deepwater gas provinces with large fields, such as Mozambique and Tanzania, are commercially developed over the next years, the enabling subsea technologies will be promptly on the market,
- In the light of the current low oil price scenarios, it is imperative to reduce the costs of the subsea production systems: re-thinking the subsea production control system (including the umbilicals) may be required. A 'Systems Engineering' approach may be beneficial in this exercise to re-define the technical requirements of equipment to be expressly designed for ultra-deepwater environment,
- Even if in some cases a very long multiphase export does not work and an offshore host is necessarily required, such as for Inpex Ichthys and Chevron Wheatstone in Western Australia and Gazprom Shtokman in the Barents Sea, Subsea-to-Beach is a field-proven offshore development concept for gas fields,
- Subsea-to-Beach projects are, and remain, valid technical alternatives to FLNG. The economic viability of these two alternatives has to be studied on a project-by-project basis.

### References

Ellaithy, W. F., Davis, H., Gaber, M., and Helal, M. F. 2004. The Scarab / Saffron Fields Development, Subsea System. Offshore Technology Conference, Houston, Texas, USA, 3–6 May 2004. OTC-16337-MS.

Brustad, S., Løken, K.-P., and Waalmann, J. G. 2005. Hydrate Prevention using MEG instead of MeOH: Impact of experience from major Norwegian developments on technology selection for injection and recovery of MEG. Offshore Technology Conference, Houston, Texas, USA, 2–5 May. OTC-17355-MS.

Acworth, W. 2006. Ultra-Long 'Offset -Subsea to Beach' Controls Technology-Case Study, Statoil Snøhvit. Society of Underwater Technology. Subsea Controls and Data Acquisition 2006: Controlling the Future Subsea, Neptune, France, 7-8 June. SUT-SCADA-06-099.

Røtjær, T. 2007. The Ormen Lange Langede Development. Offshore Technology Conference, Houston, Texas, USA, 30 April-3 May. OTC-18961-MS.

API RP 17N, Recommended Practice for Subsea Production System Reliability and Technical Risk Management, March 2009.

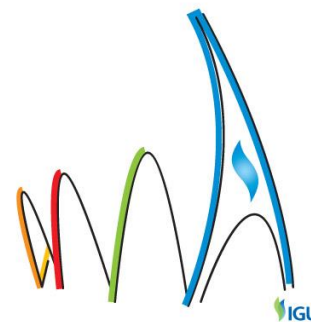

Harun, A. F., and Watt, N. C. 2009. Bringing the 1st BP Operated Subsea to Shore Gas Field into Production: Flow Assurance Lessons Learned. Asia Pacific Oil and Gas Conference & Exhibition, Jakarta, Indonesia, 4-6 August. SPE-123534-MS.

API RP 1111, Design, Construction, Operation, and Maintenance of Offshore Hydrocarbon Pipelines (Limited State Design), December 2009.

API RP 17Q, Subsea Equipment Qualification - Standardized Process for Documentation, June 2010.

DNV-RP-A203, Qualification of New Technology, July 2011.

DNV-OS-F101, Submarine Pipeline Systems, August 2012.

Bavidge, M. 2013. Husky Liwan Deepwater Subsea Control System. Offshore Technology Conference. Houston, Texas, USA, 6-9 May. OTC-23960-MS.

Healy, J., Sanford, J., Dufrene, K., Fink, J., Reeves, D., and Hopper, T. 2013. Design, Installation, and Initial Performance of Ultra-High-Rate Gas Deepwater Completions - Tamar Field, Offshore Israel. SPE Annual Technical Conference and Exhibition, New Orleans, Louisiana, USA, 30 September-2 October. SPE-166368-MS.

Rijnbeek, R. 2014. Sub Sea Compression at Ormen Lange. International Petroleum Technology Conference, Doha, Qatar, 19-22 January. IPTC-17649-MS.

Reeves, D. F., and Healy, J. C. 2014. One Tcf From One Well: The Design of a 500 MMscf/D Subsea Well for Offshore Mega Gas Fields. SPE International Symposium and Exhibition on Formation Damage Control, Lafayette, Louisiana, USA, 26-28 February. SPE-168118-MS.

Ahmed, S., Bakar, D. B. A., Elgamal, M. R., and Galal, S. K. 2015. Integrated Approach to Liquid Management for Deepwater Gas Field Developments. SPE Middle East Oil & Gas Show and Conference, Manama, Bahrain, 8-11 March. SPE-172776-MS.

### Acknowledgements

Thanks to Mike Hardy and Hatim Aboumandil for reviewing the paper; to Francesco Conte and Mike Pulvino for the stimulating technical discussions; and to Ray Vybiral and Javier Gonzales for the sketches and illustrations of this paper.